

Description

The DCxx71P6 is an uni-directional TVS diode, utilizing leading monolithic silicon technology to provide fast response time and low ESD clamping voltage, making this device an ideal solution for protecting voltage sensitive data and power line. The DCxx71P6 complies with the IEC 61000-4-2 (ESD) standard with $\pm 30\text{kV}$ air and $\pm 30\text{kV}$ contact discharge. It is assembled into an ultra-small 1.6x1.0x0.5mm lead-free DFN package. The small size and high ESD surge protection make DCxx71P6 an ideal choice to protect cell phone, digital cameras, audio players and many other portable applications.

Mechanical Characteristics

- ◆ Package: DFN1610-2
- ◆ Case Material: "Green" Molding Compound.
- ◆ Moisture Sensitivity: Level 3 per J-STD-020
- ◆ Terminal Connections: See Diagram Below
- ◆ Marking Information: See Below

Dimensions and Pin Configuration

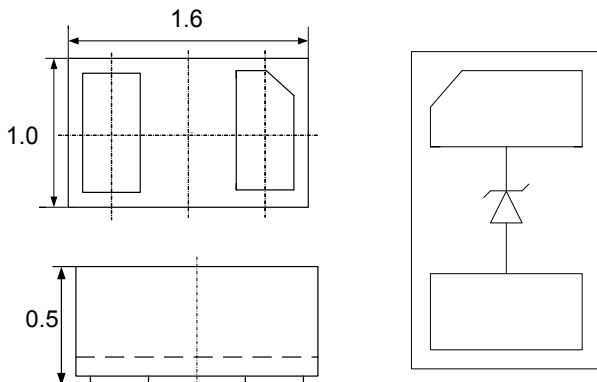

Package Dimensions (mm) Circuit and Pin Schematic

Features

- ◆ Small package: 1.6 x1.0 x0.5mm
- ◆ Protects one data or power line
- ◆ Operating voltage: 3.3V, 5V, 7V, 12V, 15V, 18V, 24V, 36V
- ◆ High peak pulse current capability
- ◆ Ultra low clamping voltage
- ◆ 2-pin leadless package
- ◆ Complies with following standards:
 - IEC 61000-4-2 (ESD) immunity test
 - Air discharge: $\pm 30\text{kV}$
 - Contact discharge: $\pm 30\text{kV}$
- ◆ RoHS Compliant

Applications

- ◆ Mobile Phones and Accessories
- ◆ Battery Protection
- ◆ USB VBus
- ◆ Power Line Protection
- ◆ Hand Held Portable Applications

Marking Information

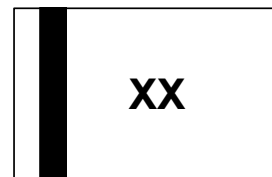

xx= Device Marking Code
Bar denotes Cathode

Ordering Information

Part Number	Marking	Packaging	Reel Size
DCxx71P6	xx	3000/Tape & Reel	7 inch

Absolute Maximum Ratings ($T_A=25^\circ\text{C}$ unless otherwise specified)

Parameter	Symbol	Value	Unit
Peak Pulse Power(8/20 μs)	Ppk	1875	W
ESD per IEC 61000-4-2 (Air)	VESD	± 30	kV
ESD per IEC 61000-4-2 (Contact)		± 30	
Operating Temperature Range	TJ	-55 to +125	$^\circ\text{C}$
Storage Temperature Range	Tstg	-55 to +150	$^\circ\text{C}$

Electrical Characteristics ($T_A=25^\circ\text{C}$ unless otherwise specified)

DC0371P6 (Marking Code: 73)						
Parameter	Symbol	Min	Typ	Max	Unit	Test Condition
Reverse Working Voltage	VRWM			3.3	V	
Breakdown Voltage	VBR	3.5			V	$I_T = 1\text{mA}$
Reverse Leakage Current	I_R			1.0	μA	VRWM = 3.3V
Forward Voltage	VF		1.0	1.2	V	$I_F = 10\text{mA}$
Peak Pulse Current	I _{PP}			150	A	$t_p = 8/20\mu\text{s}$
Clamping Voltage	VC			5.5	V	$I_{PP} = 10\text{A}$ (8 x 20 μs pulse)
Clamping Voltage	VC			12.5	V	$I_{PP} = 150\text{A}$ (8 x 20 μs pulse)
Junction Capacitance	CJ			750	pF	VR = 0V, f = 1MHz

DC0571P6 (Marking Code: 91)						
Parameter	Symbol	Min	Typ	Max	Unit	Test Condition
Reverse Working Voltage	VRWM			5	V	
Breakdown Voltage	VBR	6			V	$I_T = 1\text{mA}$
Reverse Leakage Current	I_R			1.0	μA	VRWM = 5V
Forward Voltage	VF		1.0	1.2	V	$I_F = 10\text{mA}$
Peak Pulse Current	I _{PP}			125	A	$t_p = 8/20\mu\text{s}$
Clamping Voltage	VC			9	V	$I_{PP} = 10\text{A}$ (8 x 20 μs pulse)
Clamping Voltage	VC			15	V	$I_{PP} = 125\text{A}$ (8 x 20 μs pulse)
Junction Capacitance	CJ			650	pF	VR = 0V, f = 1MHz

DC0771P6 (Marking Code: 76)						
Parameter	Symbol	Min	Typ	Max	Unit	Test Condition
Reverse Working Voltage	VRWM			7	V	
Breakdown Voltage	VBR	7.5			V	IT = 1mA
Reverse Leakage Current	IR			0.5	μA	VRWM = 7V
Forward Voltage	VF		1.0	1.2	V	IF = 10mA
Peak Pulse Current	IPP			115	A	tp = 8/20μs
Clamping Voltage	VC			12	V	IPP = 10A (8 x 20μs pulse)
Clamping Voltage	VC			16.5	V	IPP = 115A (8 x 20μs pulse)
Junction Capacitance	CJ			550	pF	VR = 0V, f = 1MHz

DC1271P6 (Marking Code: 72)						
Parameter	Symbol	Min	Typ	Max	Unit	Test Condition
Reverse Working Voltage	VRWM			12	V	
Breakdown Voltage	VBR	12.6			V	IT = 1mA
Reverse Leakage Current	IR			0.1	μA	VRWM = 12V
Forward Voltage	VF			1.2	V	IF = 10mA
Peak Pulse Current	IPP			75	A	tp = 8/20μs
Clamping Voltage	VC			18	V	IPP = 10A (8 x 20μs pulse)
Clamping Voltage	VC			25	V	IPP = 75A (8 x 20μs pulse)
Junction Capacitance	CJ			500	pF	VR = 0V, f = 1MHz

DC1571P6 (Marking Code: 75)						
Parameter	Symbol	Min	Typ	Max	Unit	Test Condition
Reverse Working Voltage	VRWM			15	V	
Breakdown Voltage	VBR	16.5			V	IT = 1mA
Reverse Leakage Current	IR			0.1	μA	VRWM = 15V
Forward Voltage	VF			1.2	V	IF = 10mA
Peak Pulse Current	IPP			60	A	tp = 8/20μs
Clamping Voltage	VC			22	V	IPP = 10A (8 x 20μs pulse)
Clamping Voltage	VC			31.25	V	IPP = 60A (8 x 20μs pulse)
Junction Capacitance	CJ			450	pF	VR = 0V, f = 1MHz

DC1871P6 (Marking Code: 78)						
Parameter	Symbol	Min	Typ	Max	Unit	Test Condition
Reverse Working Voltage	VRWM			18	V	
Breakdown Voltage	VBR	19.6			V	IT = 1mA
Reverse Leakage Current	IR			0.1	μA	VRWM = 18V
Forward Voltage	VF		1.0	1.2	V	IF = 10mA
Peak Pulse Current	IPP			50	A	tp = 8/20μs
Clamping Voltage	VC			26	V	IPP = 10A (8 x 20μs pulse)
Clamping Voltage	VC			37.5	V	IPP = 50A (8 x 20μs pulse)
Junction Capacitance	CJ			350	pF	VR = 0V, f = 1MHz

DC2471P6 (Marking Code: 74)						
Parameter	Symbol	Min	Typ	Max	Unit	Test Condition
Reverse Working Voltage	VRWM			24	V	
Breakdown Voltage	VBR	26.7			V	IT = 1mA
Reverse Leakage Current	IR			0.1	μA	VRWM = 24V
Forward Voltage	VF			1.2	V	IF = 10mA
Peak Pulse Current	IPP			35	A	tp = 8/20μs
Clamping Voltage	VC			42	V	IPP = 10A (8 x 20μs pulse)
Clamping Voltage	VC			53.5	V	IPP = 35A (8 x 20μs pulse)
Junction Capacitance	CJ			200	pF	VR = 0V, f = 1MHz

DC3671P6 (Marking Code: 79)						
Parameter	Symbol	Min	Typ	Max	Unit	Test Condition
Reverse Working Voltage	VRWM			36	V	
Breakdown Voltage	VBR	37			V	IT = 1mA
Reverse Leakage Current	IR			0.1	μA	VRWM = 36V
Forward Voltage	VF			1.2	V	IF = 10mA
Peak Pulse Current	IPP			25	A	tp = 8/20μs
Clamping Voltage	VC			60	V	IPP = 10A (8 x 20μs pulse)
Clamping Voltage	VC			75	V	IPP = 25A (8 x 20μs pulse)
Junction Capacitance	CJ			150	pF	VR = 0V, f = 1MHz

Typical Performance Characteristics (TA=25°C unless otherwise Specified)

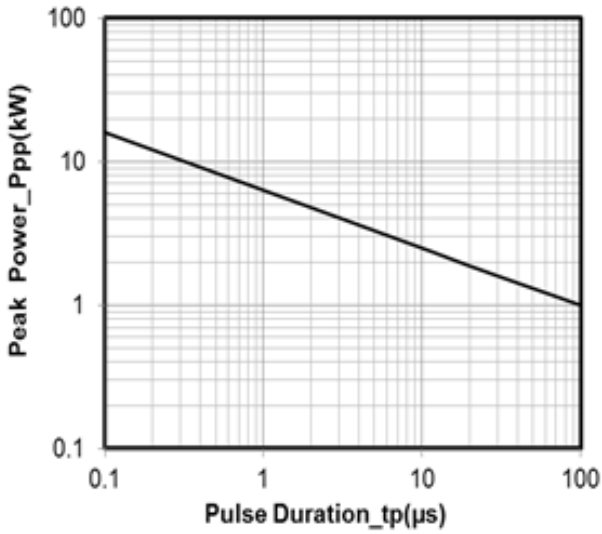

Junction Capacitance vs. Reverse Voltage

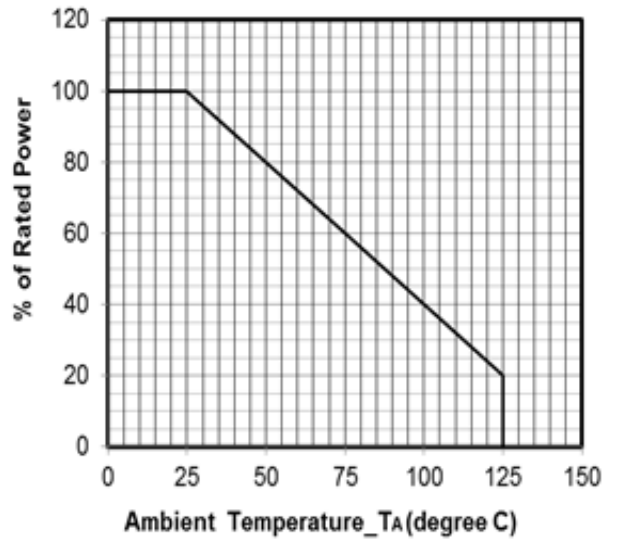

Power Derating Curve

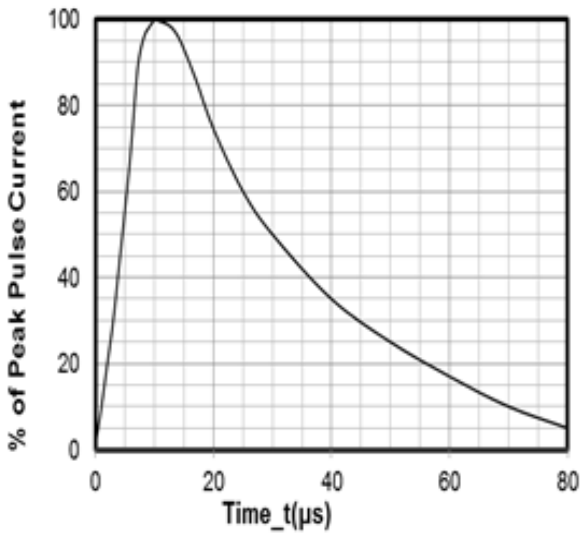

8 X 20 s Pulse Waveform

